

Anti-Vibration Solutions for Railways, Automotive and Other Industries

Industry leader in manufacturing over hundreds of Rubbers and Thermoplastics based Moulded Anti-Vibrations, Mounts, Buffers, Dampers, Suspensions, Torsion Blocks, Silent Blocks, Bushes, Metal Bonded Parts and other polymeric engineering products for static and dynamic application for Railways and Roadways Sector.

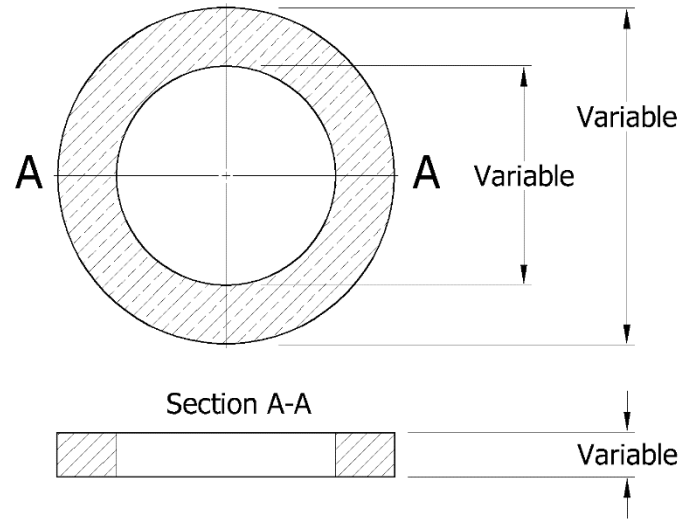
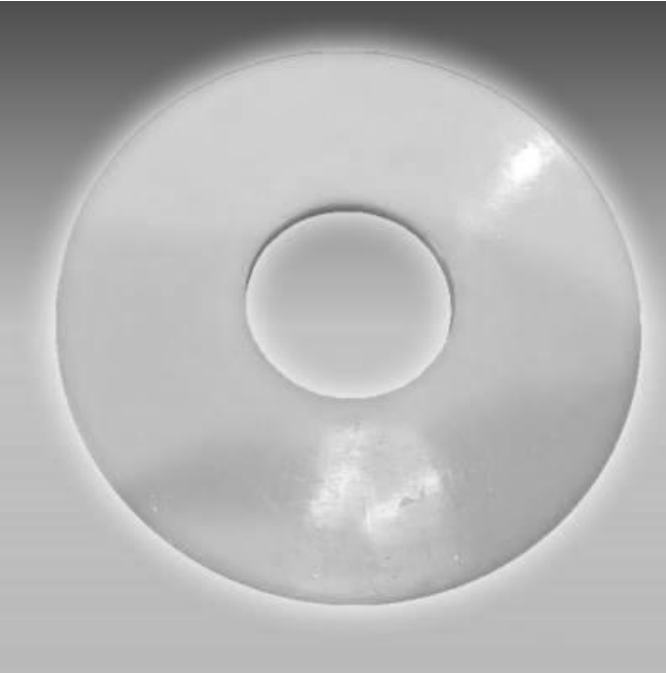

BRIEF DESCRIPTION

Spring Protection Pads or Happy Pads are used below and above the primary helical coil springs of Railway Locomotives and Passenger Coaches to minimize sudden impact by means of shock absorption, reduced fretting and damping for ultimate enhancement of service life of coil spring. These pads also eliminate direct metal to metal contact between helical coil spring, bolster and centring plate reducing noise of the assembly. The most important property of this type of pads are very high hysteresis loss yielding effective damping on coil springs. The product is designed to perform in various weather conditions from dry to humid, hot to cold.

PRODUCT APPLICATION

Thermoplastic Pads for Dynamic Application

WORKING LOAD RANGE

5000 Kg [Compressive] and beyond. This range is customisable.

WORKING TEMPERATURE RANGE

Works in ambient temperature between -40°C to 60°C. This range may be customised as per users' requirement.

MOSTLY USED IN

Various Diesel and Electric Locomotives, and Passenger Coaches

RELATED DOCUMENTS

- 1) MP-0-40-99-01